

# SON Schmidt's Original Nabendynamo

## Instructions for Use SONdelux

Schmidt's Original hub dynamo SONdelux in combination with Edelux LED headlight is licensed for wheels 16"-28", i.e. 400 to 716 mm outer diameter (VVV K 687). Other high grade LED headlights are also suitable, such as Lumotec IQ Cyo by Busch & Müller; yet without the German legal mark of conformity.

The SONdelux yields the nominal power of 3 Watt in a 20" wheel at 14 km/h, in a 700c wheel only at 19 km/h. This way it takes very low power input when running idle as well as with lights switched on.

Nevertheless, with Edelux, you achieve 50 Lux at a speed of 15 km/h already.

The following instructions should be followed carefully. Better leave the spoking to specialists. Please go to the end of these instructions for more details.

### Fitting the Front Wheel

The SONdelux is suitable for fitting in forks with 100 mm fork width and 9 mm axle slot. The electrical connections may be placed either on the left or on the right side. The front wheel is fastened with a standard skewer (an Allen fitting, a quick release or anti-theft device). The shaft of the bolt should not be greased to prevent clogging of the pressure compensation system. It is indispensable that you regard the manufacturer's instructions.

Concerning the Allen skewer delivered with SONdelux please note:

**Thread and bolt head should first be greased, but *not* the shaft of the skewer!**

**Fasten the SONdelux with a tightening torque of 6 - 8 Nm at the Allen skewer!**



If the skewer is tightened insufficiently, the axle might move in the fork slots causing a rattling noise.

Instead of the hex skewer you may also use a commercially available quick release or a skewer axle with theft protection (e.g. Pitlock). Please observe the instructions of the manufacturers of these items.

### Fitting the Headlight

Wiring an Edelux is quite simple, if the connectors are already mounted to its coaxial cable. Pass the cable along the inside of the fork blade to the SON and plug it in (contacts arbitrarily interchangeable). Fasten the cable with zip ties at the fork so that plugs can be easily disconnected before the wheel is removed.

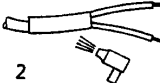
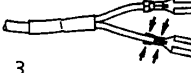
To mount the headlight further away from the hub, it is also available with a longer cable. Female connectors (4.8 x 0.8 mm) and shrink tubes are enclosed and should be fitted as follows:

 <p>1</p>	<ul style="list-style-type: none"> <li>• Cut cable to length and strip carefully over a length of approx. 4 cm</li> <li>• Twist the ends of the outer wires</li> </ul>
 <p>2</p>	<ul style="list-style-type: none"> <li>• Strip the inner conductor about 5 mm</li> <li>• Heat the 32 mm piece of thin shrink tube with flame or a hot air gun to shrink it onto the outer conductor</li> <li>• Shrink a fat piece of shrink tube onto the junction</li> </ul>
 <p>3</p>	<ul style="list-style-type: none"> <li>• Fit the female connectors</li> <li>• Crimp the plugs on with a crimping tool or pointed pliers (if in doubt, solder as well); the first pair of claws must grip the insulation</li> </ul>
 <p>4</p>	<ul style="list-style-type: none"> <li>• Shrink on the shrink tubes.</li> <li>• Grease the plugs a little, so you can push the contacts onto the SON hub dynamo more easily.</li> </ul>

Switched headlights from other manufacturers have twin-wire cables in place of coaxial cable. Instead of steps 1 and 2, just cut the cable to a suitable length, separate the two conductors over a length of around 3 cm and insulate the ends for about 5 mm.

### Connecting the Rear Light

**The SONdelux has a nominal power of 3 Watt. It is therefore designed to operate a rear light and a headlight. If you run a headlight on it only, the headlight will take up the higher power. This is uncritical for the Edelux, for other LED headlights however not necessarily.**

We recommend a high quality LED rear light with capacitor standlight (e.g. Toplight D plus or Toplight line plus by B&M).

In order to be able to switch the rear light on and off it has to be connected to the switched headlight. If headlight and rear light have an earth connection with the frame (the SON itself has no earth connection), a single wire can be laid for this purpose. Better use twin wire. The ready-made coaxial rear light cables by Schmidt are the most reliable solution.

## Care and Maintenance

The generator itself is optimally protected within the hub and is fully wear and maintenance free as it works without gears or contact. Wiring and light system however, have to be checked regularly and in case of a defect must be immediately repaired because of the high idling voltage.

**To prevent water ingress, the hub should never be exposed to strong jets of water (hose, pressure washer) or immersed in water.**

**The deep groove ball bearings of the hub are permanently lubricated and also maintenance free under normal conditions of usage, i.e. they cannot be adjusted and require no further lubrication.** A small amount of play is normal in deep groove ball bearings and will not result in damage.

**The SONdelux aluminium axle and the parts on it have no threads so that nothing can or may be twisted.**

**For the SONdelux there is a guarantee period of 5 years.** In case of problems ask your dealer to contact the manufacturer or the importer. Please enclose a copy of your proof of purchase.

## Important Notes

**A hub dynamo generates high voltage when lights are switched off and at the very moment of switching it off. Touching it in such a moment might be painful or even dangerous!** For this reason, careful, contact-free wiring must be ensured. This applies in particular when a separate switch is used.

**The pole sensitivity of the dynamo (resistance when turning the axle by hand) is a feature of the claw pole generator and has nothing to do with the smooth running of the bearings.**

SON hub dynamos might interfere with the function of bicycle computers with radio transmission.

## Wheelbuilding

The SONdelux is designed for the usual crossed form of spoking. Flange width and spoke holes are optimised for high-quality 2 mm spokes.

To calculate the correct spoke length you need the radius  $r_2$  of the rim. The rim diameter is measured between two opposing nipple head seats and divided in halves.

A table with spoke lengths and information on calculation are available online at [www.nabendynamo.de](http://www.nabendynamo.de)

The spoke length can be calculated by the rule of thumb:

For 26"-28" rims: 32 hole, 3x crossed:  $l \approx r_2 - 8.5 \text{ mm}$

36 hole, 3x crossed:  $l \approx r_2 - 12 \text{ mm}$

For 16"-20" rims: 32 hole, 2x crossed:  $l \approx r_2 - 17.5 \text{ mm}$

Spokes which are 1 mm shorter than the thus calculated value may also be used.

**The protective plastic wrapping on the hub's body shields against scratches through threading in the spokes. Please do not remove it until the wheel is fully spoked.**

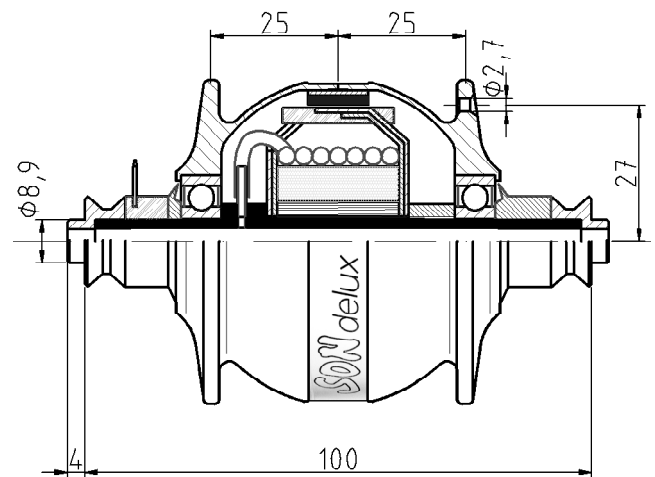

## Manufacturer

Wilfried Schmidt Maschinenbau  
[www.nabendynamo.de](http://www.nabendynamo.de)