

SON Schmidts Original Nabendynamo

Instructions for Use **Edelux**

LED-headlight with switch/automatic sensor and standlight function

The Edelux is especially designed for use with gearless hub dynamos. The provided or already assembled plugs fit the Schmidts Original Nabendynamo (SON), but the light's use with other hub dynamos is also possible. The most important characteristic of the Edelux is the outstanding light technology, which achieves a wide and even illumination of the road. The optical system („IQ-TEC“-mirror) was developed by Busch & Müller. Rugged mechanical design, reliable electrical contacts and good sealing ensure problem-free operation in daily use, regardless of weather. Efficiency and LED life span depend on its cooling. Therefore the LED is placed on a copper heat sink, which in turn conducts the heat to the aluminium housing.

Assembly on the Bicycle

Mount the Edelux with standard headlight brackets. Firmly tighten the screw connections so that the headlight cannot move by itself. However, it should be possible to correct the beam angle by hand.

Align it in such a way that it creates an ideally long light field without dazzling oncoming traffic.

Attachment to the fork bridge of a suspension fork results in a high swinging load for the bracket. Therefore mounting on the handlebars or stem is preferable on bicycles with front suspension.

Wiring to the Dynamo Hub

Wiring of an Edelux is quite easy, if the connectors are already mounted to its coaxial cable. Pass the cable along the inside of the fork blade to the SON and plug it in (contacts arbitrarily interchangeable). Fasten the cable with zip ties at the fork in such a way that the plugs can be easily detached before removing the wheel.

If the plugs are not fitted cut the cable to a suitable length and connect the plugs enclosed in the following way:

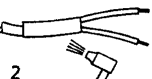
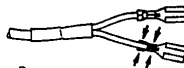
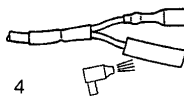
 <p>1</p>	<ul style="list-style-type: none"> • Cut cable to a suitable length and carefully remove about 4 cm of outer insulation • Twist the underlying wires together with caution
 <p>2</p>	<ul style="list-style-type: none"> • Strip the inner conductor about 5 mm • Heat the 32 mm piece of thin shrink tube with flame or a hot air gun to shrink it onto the outer conductor • Shrink a fat piece of shrink tube onto the junction
 <p>3</p>	<ul style="list-style-type: none"> • Fit the plugs, using a crimp tool or pliers to secure both the insulation and the cables. The first pair of claws must grip the insulation (in case of doubt solder additionally)
 <p>4</p>	<ul style="list-style-type: none"> • Slide and shrink a piece of fat shrink tube over each plug • Grease the plugs a little, so you can push them onto the SON hub dynamo contacts more easily.

For connection to other hub dynamos see their instruction manual.

At hub dynamos with integrated overvoltage protection the Edelux does not reach full brightness.

If one contact of the dynamo is electrically connected to the frame (e.g. all models of Shimano), the wires are no longer interchangeable: The outer conductor of the coaxial cable (not insulated or covered with black shrink sleeve) must be connected to the ground \perp , the transparent insulated interior wire must be connected to the phase contact of the dynamo.

Connection of a Rear Light

The Edelux is designed for operation on a 6V 3W hub dynamo together with a commercially available LED rear light. However, it may also be used without a rear light.

Connect the rear light to the Edelux, so you can control it also with the switch of the Edelux. Preferably use the included 2.8 mm plug to connect the rear light cable at the blade terminal of the Edelux; mount according to pictures 3 and 4 of the table above. The plug must be covered with a heatshrink tube or else a short-circuit with the aluminium housing might occur. An earth connection to the rear light is not compulsory, yet it increases reliability. Most reliable are Schmidt's ready-made coaxial cables. Connect the earth conductor with the included ring terminal at the fixing screw of the Edelux. When using a rear light with earth connection mind its polarity.

Switch - Automatic Sensor - Standlight

The switching contact is placed, optimally protected, inside the headlight base. It is controlled by a magnet in the black switching ring. The automatic light sensor is active when the nose of the switching ring points up ('S'), i.e. the light turns on automatically in beginnings of darkness. When you switch the nose to the left position ('0'), as viewed from the rear, the light is turned off permanently; in the position to the right ('1') it is switched on. Should the switching ring be pulled off for once, put it back correctly onto the housing: seen from the back, the '1' should be on the left and the '0' on the right side of the nose. If the switching ring should be missing, the Edelux is in sensor-mode.

After a short ride with light switched on standlight will be available. The standlight capacitor is completely charged after riding continuously for 5 minutes. It will then provide standlight which shuts down automatically after 4 minutes.

Battery-powered use of the Edelux is not recommended. Voltage higher than 7.5 V – even for a very short time – may damage electronics and LED. Though voltage lower than 6.5 V is uncritical, it reduces brightness.

Overvoltage Protection

The electronics within the Edelux limits the output at the rear light to 9 Volt and in this way protects LED-rear-lights of overvoltage. Rear lights with bulbs should not be applied together with the Edelux.

Guarantee/Spare Parts

The Edelux does not contain any parts that need maintenance. **Do not try to open the headlight!** You might damage sealing, screwed connections and electrical insulation.

The switching ring is available as a spare part.

For the Edelux there is a guarantee period of 5 years. In case of problems ask your dealer to contact the manufacturer or the importer. Please enclose a copy of your proof of purchase.

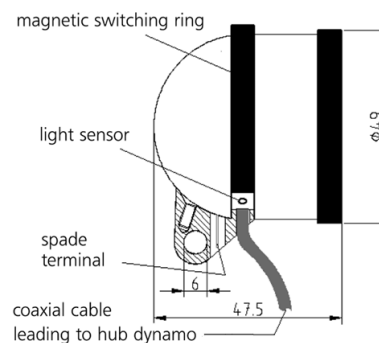

Manufacturer

Wilfried Schmidt Maschinenbau
www.nabendynamo.de